



Turbine Flowmeter Series TM44



Series TM44 Turbine Flow Meter

Working pressure manufacturing according to
PED 97/23/CE (Lloyd's Register Certificate N° 031)

For the measurement of Flow Rate or Volume
Totalisation

- Accuracy better than $\pm 0.5\%$
- Standard Construction:
 - Body: EN 1.4404 (SS 316L)
 - Propeller: EN 1.4416 (SS 430)
 - Spindle: Tungsten
 - Bearing: Graphite
- Sizes: DN10 to DN500
- Flow rates:
 - Water: 100 l/h up to 6700 m³/h
- Low Pressure Drop
- Vertical or horizontal installation
- Explosion Proof enclosure available for hazardous environments
- Connection:
 - Standard: Flanges EN 1092-1, PN40...PN16
 - On Request: Up to PN200, ANSI Flanges, BSP, NPT threads, etc.

Applications

The standard TM44 turbine flow meter is resistant to most severe process fluids including acids, alkali, solvents, water, CIP fluids, oil, minerals, petrochemical products, cryogenic liquids, and other liquids.



TM44 Turbine flow Meter

Operation

Free turning rotor (propeller) is contained within a tube. A liquid flowing through the cylinder will apply a force to the blade of the rotor causing it to rotate at a speed proportional to the velocity of the fluid. The proportional relationship applies over a wide range of flow and viscosity.

Each complete turn of the rotor corresponds to a set volume, which is very repeatable for a given fluid. An inductive sensor, external to the process, detects each pass of the rotor's blades. Each pulse of the sensor corresponds to the passing of a set volume of fluid and the frequency of the signal corresponds to the flow rate.

The TM44 can be supplied as a basic sensor with a pulse output or a 4-20mA output. Alternatively, a number of electronic units are available to provide batch control, totalisation and a display of instantaneous flow rate.

The TM44 is factory tested and supplied with a calibration certificate identifying the precise volume per pulse for the individual flow meter.

Nº	Part name	Materials
1	Body	EN 1.4404 (SS 316L)
2	Circlips	EN 1.4404 (SS 316L)
3	Outlet deflector	EN 1.4404 (SS 316L)
4	Main Spindle	Tungsten
5	Bearing	Graphite
6	Propeller	EN 1.4416 (SS 430)
7	Disc	Tungsten
8	Stop Spindle	Tungsten
9	Inlet deflector	EN 1.4404 (SS 316L)
10	Coil	—
11	Coil support	EN 1.4305
12	Connector base	Anodized Aluminium
13	Connector	Anodized Aluminium
14	Seal	NBR
15	Seal	PTFE

Technical Data

- Connections:
 - Standard: EN 1092-1 Flanges DN10 to DN500 PN16
 - On Request: Up to PN-200, ASA Flanges, BSP, NPT, etc.
- Pressure: Standard PN40...PN16 depending on size, on request up to 3000 bar
- Temperature: Standard from -50°C to +130°C, on request from -100°C to +250°C
- Accuracy: ±0.5%
- Repeatability: ±0.05% to 0.1%
- Rangeability: 10:1
- Response: 10 ms
- Output Signal: 10...6200mV for flow min-max
- Materials: Body in EN 1.4404 (SS 316L)
Propeller in EN 1.4416 (SS 430)

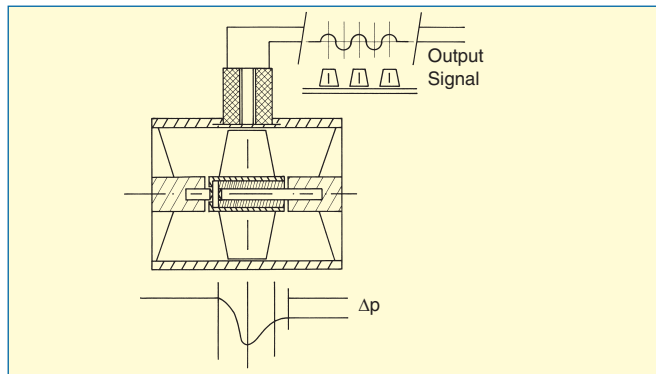

DN	Minimum Flow m³/h	mV	Maximum Flow m³/h	mV
15	0.3	10	3000	92
20	0.6	182	6000	1070
25	0.9	260	13.5	2600
40	1.9	36	27	400
50	5	270	50	1360
65	9	680	90	4800
80	15	760	150	6200
100	28	760	184	4600
150	65	800	250	2800

Output Signal mV/pulse (without amplifier), as a function of flow.

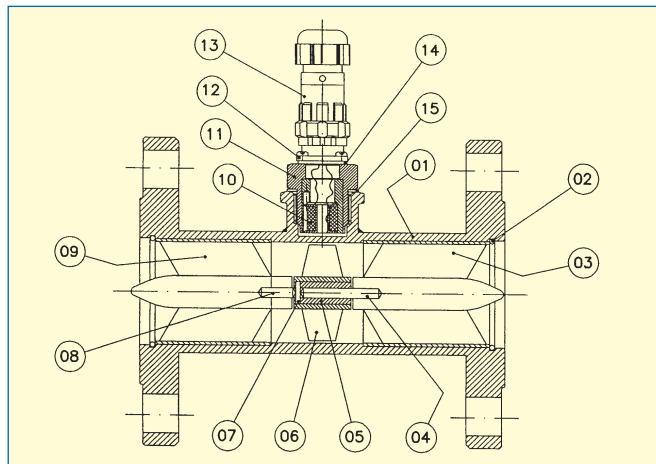

- Electrical Connection:
 - Standard: Hermetically sealed IP65
 - On request: Explosion Proof enclosure
- Recommended cable:
 - Shielded, twisted pair, until 30 m
 - Up to 100 m using the APTM44 amplifier
 - Up to 3000 m, using the converter Hz/mA series CI-420

Hazardous Zone

Explosion Proof enclosures are available for the electronic units MC01, MT02 which enable visual and operator access to Genelec EEx d IIC T6.

Installation

Horizontal or Vertical up to DN80/DN100. For larger sizes, only horizontal installation is recommended.

In accordance with the standard API 2534, it is necessary to provide a straight pipe section of 10 pipe diameters before the turbine and 5 pipe diameters downstream.

For the best performance from the TM44, a filter before the flow meter is recommended. A mesh size of 1mm² is required for sizes up to DN80/DN100 and 3mm² for DN125 and greater.

In all the liquid applications that may contain entrained air or gases, a de-gassing chamber is recommended prior to the flow meter. This will ensure an accurate measurement of flow or volume is always obtained.

To avoid cavitation inside the chamber of the turbine meter, it is recommended that the API standard is followed. That is, the output pressure of the turbine should always exceed double the pressure drop of the measurement and more than 1.25 times the vapour pressure of the liquid or its most volatile component.

Important: Low voltage signals are used between the TM44 and its electronic unit. The cable must be kept clear of any power cables or other cables that may cause interference with the signal.

Density and Viscosity

The standard operating ranges of the TM44 are based on water with a density of 1kg/L and viscosity of 1mPas. With the supply of each flow meter a calibration certificate is provided which accurately specifies the output pulses/litre for the specific flow meter.

Variations in viscosity will alter the number of pulse/litre but it will not affect the repeatability of the measurement for the same liquid. The errors associated with variations in viscosity are shown in Figure 2.

Variation in the fluid density and/or viscosity will affect the pressure drop across the flow meter in accordance with Figure 3.

In general, variations in viscosity or density will only affect the "low flow" reading in the TM44. Liquids with a density less than 1kg/l have a higher minimum flow and liquids with a density greater than 1kg/l will have a lower minimum flow.

Generally, the effect of density is insignificant. Any liquid density would not alter the scale, based on water, more than 5-7% of the calibration range.

Typical Installation

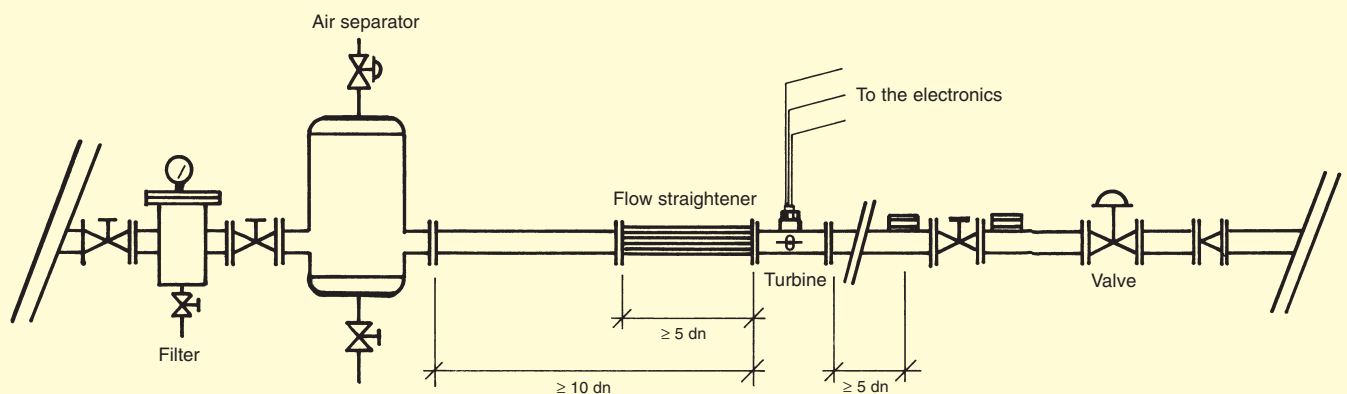



Turbines TM44

Flows vs Pressure Drop, for water

% Errors vs Flow (liquid 1 kg/l, 1 mPa.s)

Figure 1

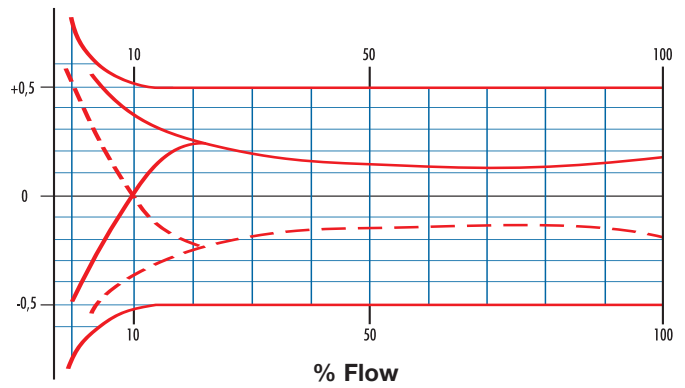
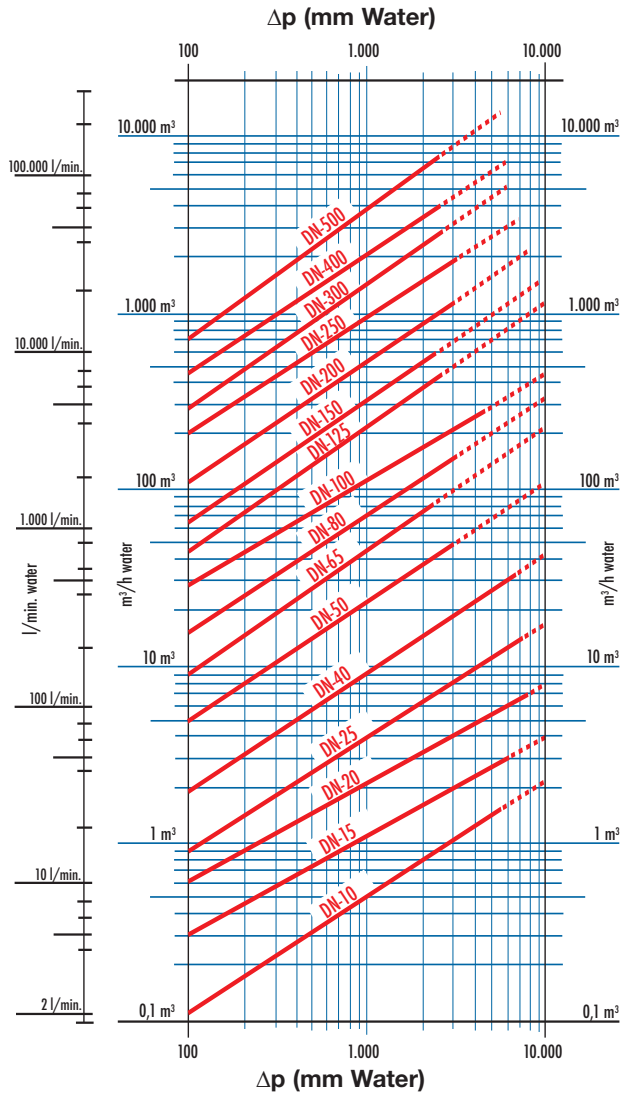

Viscosity Effect, for Liquids

Figure 2

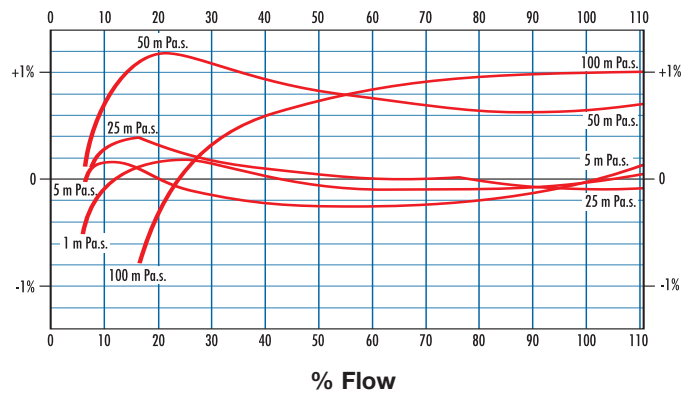

Δp (mm Water) vs Density & Viscosity

Figure 3

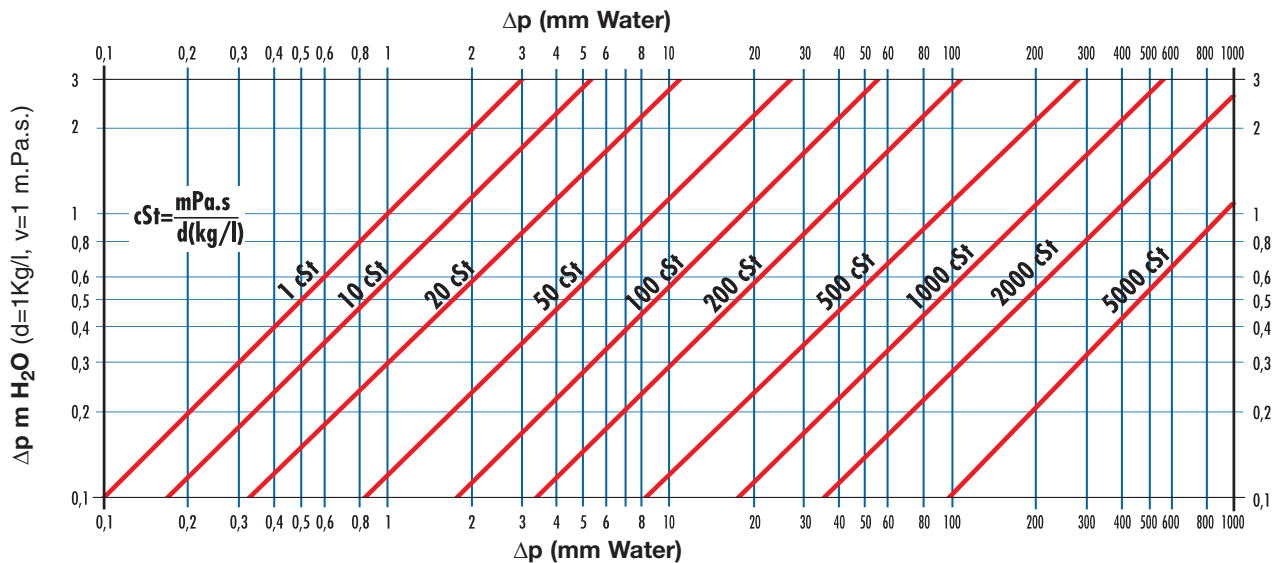

Dimensions & Weights. Flanges according to EN 1092-1

DN	D	k	g	l x n°	b	Flange PN	L	H	HAD	Wt (kg)
10	90	60	40	14x4	14	40	100	99	97	1.6
15	95	64	45	14x4	14	40	100	99	97	1.9
20	105	75	58	14x4	14	40	100	99	97	2.1
25	115	85	68	14x4	18	40	130	99	97	3.6
40	150	110	88	18x4	18	40	150	106	107	6.2
50	165	125	102	18x4	20	40	180	112	112	7
65	185	145	122	18x4	20	16	200	119	119	10
80	200	160	138	18x8	20	16	230	127	127	12
100	220	180	158	18x8	20	16	250	136	136	17
125	250	210	188	18x8	22	16	280	149	149	21
150	285	240	212	23x8	22	16	300	161	161	27
200	340	295	268	23x8	24	10	400	192	192	50

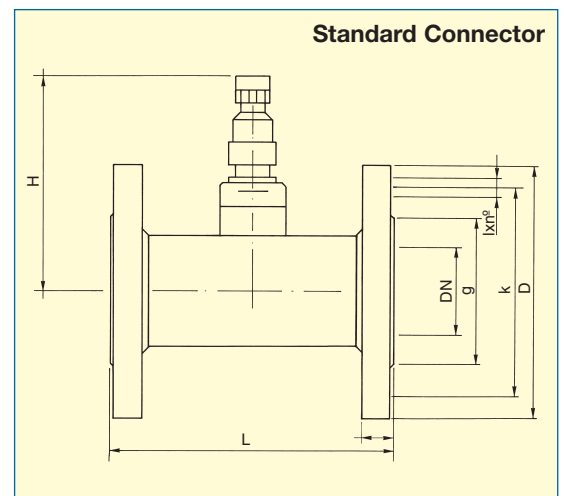
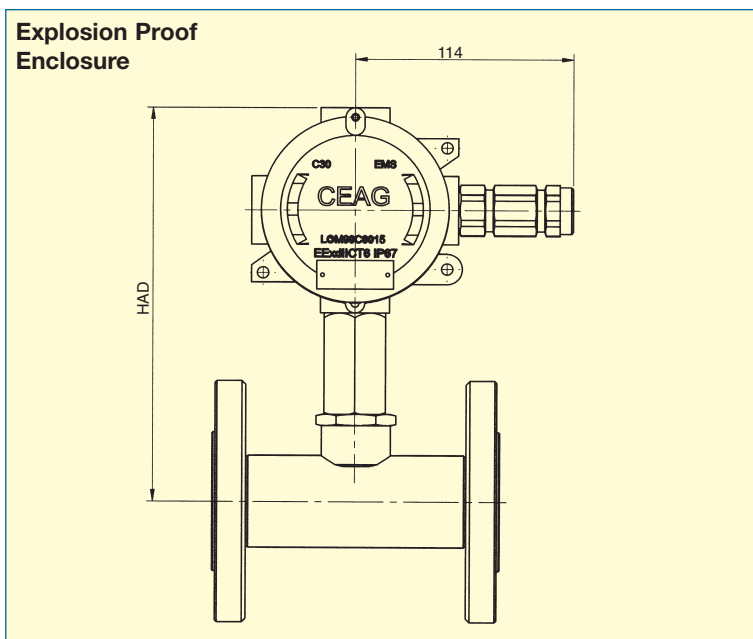

Flow Rates

DN	Flow (m³/hr)		Flow Limit (m³/hr)	Pulses/l ±10 %	Δp (mm Water) max Flow
	Min.	Max.			
10	0.2	1	1.4	2,500	7,500
15	0.3	3	4	730	7,500
20	0.6	6.8	8	500	7,500
25	0.9	13.5	16	220	7,000
40	1.9	30	40	60	5,600
50	5	50	60	20	2,800
65	9	90	115	10	2,400
80	15	150	180	5	3,100
100	28	280	340	3	4,500
125	45	450	560	1.5	2,400
150	65	650	820	0.8	2,500
200	110	1,100	1,300	0.3	2,800

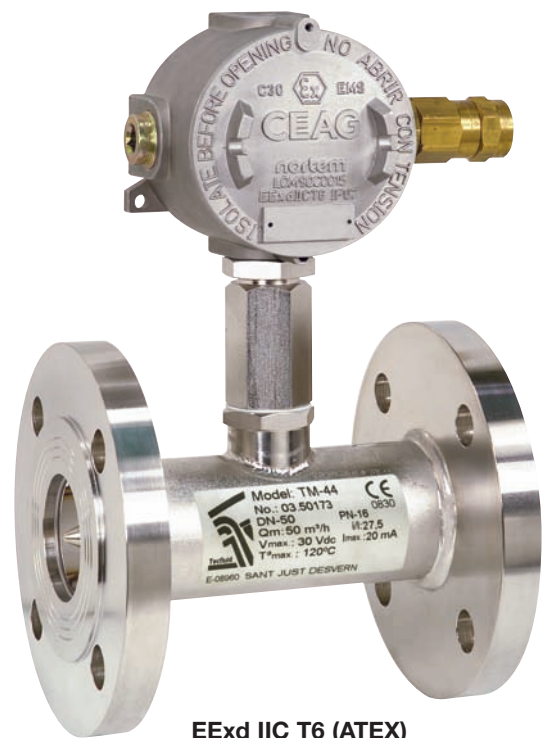

EEExd IIC T6 (ATEX)



MC-01/MT-02 series Electronic Control Units

The MC-01 and MT-02 series, are panel mounting micro-processor based control instruments for batching control.

MC-01

Applications

- Automated process control in any industry with flow rate

Benefits

- Direct interface to Turbines, Covol etc.
- Direct interface for analog inputs
- Fully programmable by user
- Battery back-up stores all data on power failure
- Flow rate readout in l/h and m³/h
- Adaptive filter gives stable flow rate readings
- Volume totalizing counter
- Volume partial counter
- Batching relay
- 16 character x 2 line LCD alpha-numeric display
- Optional remote start push button for batching
- Analog output for process control 0...4-20 mA, 0-10V
- Standard DIN 96 x 96 panel mounting
- Plug in connections with screw terminals for easy installation and maintenance
- Optional IP-65 front protection
- Power supply: 110, 220-240, 24 V ac 50-60 Hz
12 (not with analog output), 24 Vdc
- Power consumption: < 3 VA
- Input signal TM-44: 20 mV... 3 V ac, 0....2000 Hz
- Input signal COVOL: Reed contact, 0....100 Hz
- Input signal Analog: 0-20 mA, 4-20 mA, 0-5 V dc, 0-10 V dc, 1-5 V dc, 2-10 V dc
- Remote batch start: By means of a push button
- Precision: 0.01% (0.4% analog input)
- Temperature range: -10°C.....60°C
- Analog output: 12 bit resolution
- Relay: 1 A, 250 V ac, 60 VA



MC-01 (with optional front protection)

They are fully user programmable and will adapt directly to anyTM-44 turbine, COVOL, TTL output, or equivalent pulse generating output trasducers.

MT-02

Applications

- Automated process control in any industry with batching or volume control

Benefits

- Very easy to use
- Bright LED display, 7 digit data, 1 digit mode
- Direct interface to Turbines, Covol etc.
- Fully programmable by user
- Battery back-up stores all data on power failure
- Volume totalizing counter
- Volume partial counter
- Batching relay
- Remote start push button for batching
- Standard DIN 96 x 96 panel mounting
- Plug in connections with screw terminals for easy installation and maintenance
- Dual relay version for fast aproximation and slow finish (two control valves)
- Centesimal version for small flowmeters
- Optional interface with 12 and 5 volt proximity detectors
- Power supply: 110, 220-240, 24 V ac 50-60 Hz
24 Vdc



MT-02

Dimensions

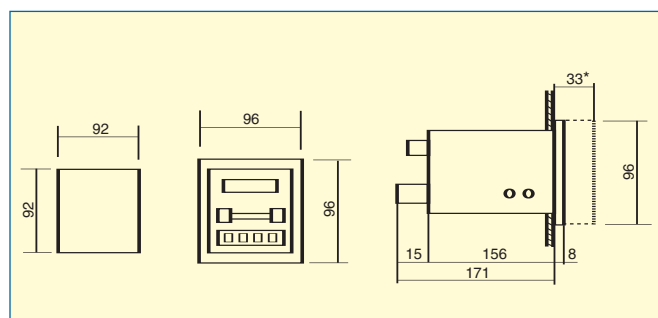

*with optional front protection

CIP, CIP II Compact mounted TM44 volume counter

Compact system featuring:

- TM44 turbine body and electronic counter mounted together to form a compact unit
- Same flow rates, pressures and other working conditions as for TM44 series
- CIP electronic counter mounted in IP65 housing with an injected aluminium base and U.V. treated polycarbonate cover
- Programmable pulses/unit factor
- Button battery power supply lasts for 30.000 hours (3-4 years)
- CIP: 7 digit, 9 mm digit size
- CIP II: 7 digit, 8 mm digit size for totalizer counter
5 digit, 6 mm digit size for partial counter
- Counter reset by means of internal push button or 4 external magnet (CIP II totalizer counter cannot be reset)

TM44 with CIP, CIP II & CH420L



Dimensions TM44 with CIP, CIP II & CH420L

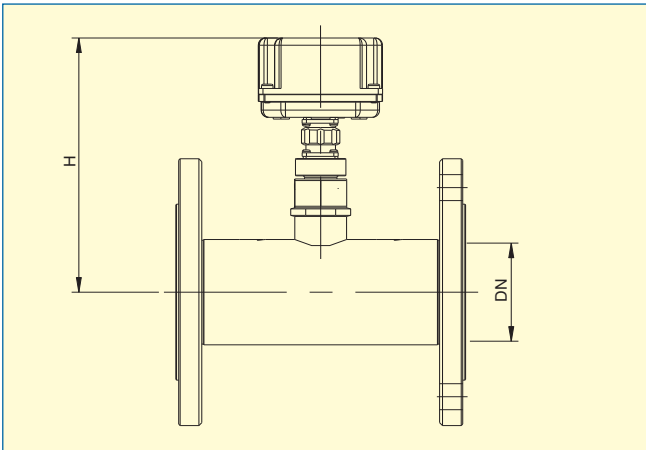

DN	H
DN10	145
DN15	150
DN20	152
DN25	155
DN40	162
DN50	167
DN65	175
DN80	182
DN100	192
DN125	205
DN150	217
DN200	242

Dimensions

CIP, CIP II & CH420L

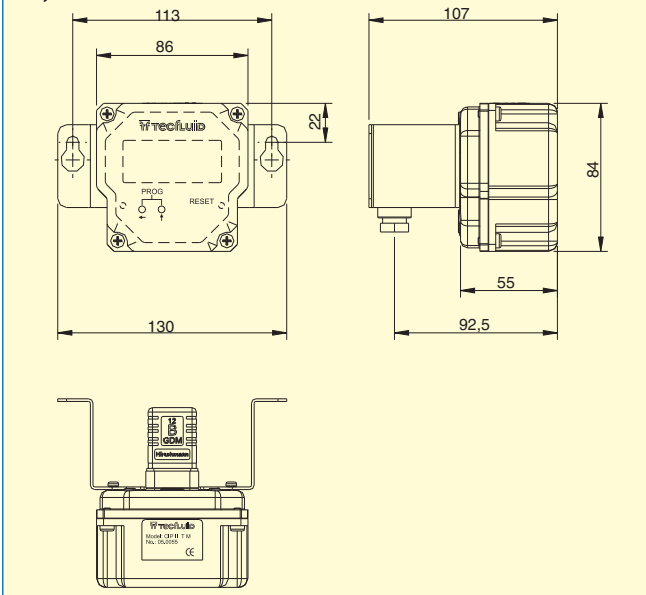

CH420R

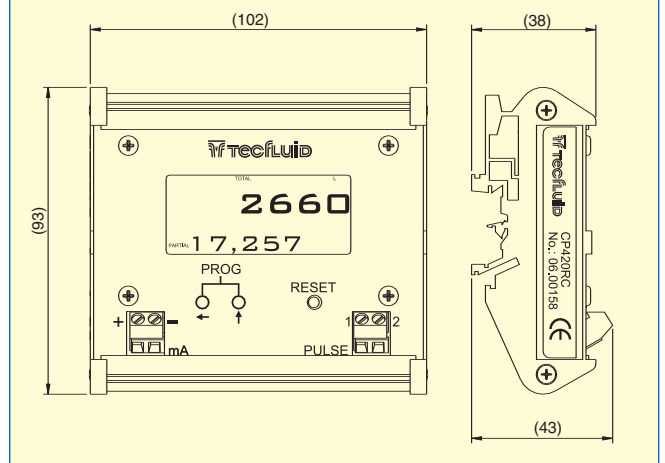

Flow Transmitters and Volume Counter



CH420L



CH420R

Characteristics

- HART protocol communications
- Connects directly to a COVOL or TM-44 turbine
- CH420L for compact mounting (local)
- CH420R for DIN rail mounting (DIN 46277)
- Programmable pulses/litre
- Programmable beginning and end of analog scale
- Selection of various types of units for flow rate and totalizer

- Power supply from two wire current loop
- Working voltage: 7,5...36 Vdc
- Current consumption: less or equal to 20 mA
- Totalizer: 7digits, 8 mm high
- Flow rate: 5 digits, 6 mm high
- Totalizer reset by means of a push button
- Ingres protection: IP65(CH420L)
IP30(CH420R)
- Ambient temperature: 0...+60°C

(Dimensions pag. 7)

EExd IIC T6 (ATEX) Enclosure

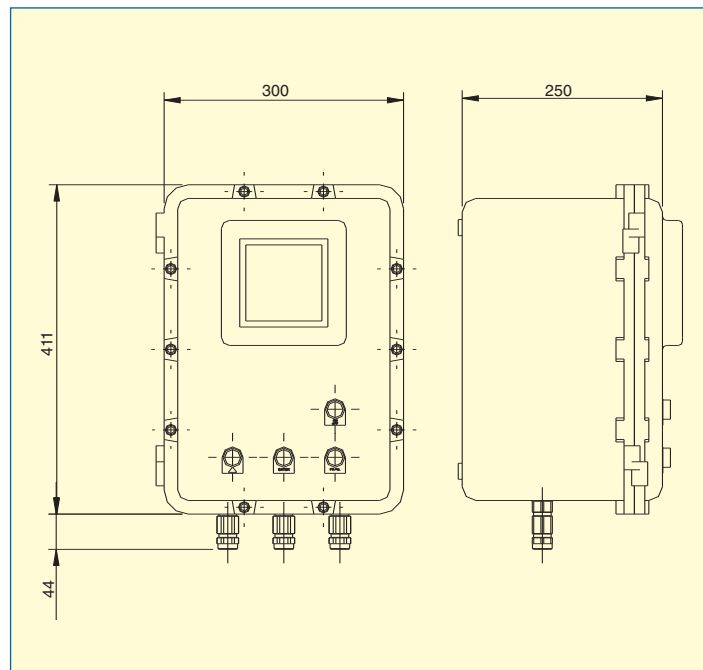

DFD-2 series Electronics Frequency Dividers

The DFD-2 series are rail mounting (DIN 46277) micro-processor based control instruments for frequency division. They are fully user programable and will adapt directly to any TM44 turbine, COVOL output, or equivalent pulse generating output transducers.

Applications

- Automater process control in any industry with batching or volume control for interfacing with PLC
- Interface with slow scanning PLC inputs
- Interface with PLC without calculations capacity
- Interface with simple counters
- Interface for electromechanical totalizing counters

Benefits

- Very simple to use
- Direct interface to Turbines, Covol etc.
- Fullt programable by user
- Standard DIN rail mounting
- Connections with screw terminals for easy installation and maintenance
- No batteries needed, BCD switch programming

Technical Data

- Power supply 110,230,240,24 V ac 50-60 Hz
12 V dc
- Power consumption < 1 VA
- Input signal TM-44 20 mV...3 V ac, 0....2000 Hz
- Input signal COVOL Reed contact, 0....100 Hz

- Precision No lost pulses
- Temperature range -10°C.....60°C
- Output / input range 0.00000001.....0.49999
- Output signal Open Collector 0.1 A 40 V
TTL (5V)
- Output pulse width approx. 50%
duty circle

Ordering Information

DFD-2 / a / vvv

- a** = **Input Type**
- = 1 COVOL
 - = 2 Turbine Pick-up
 - = 3 TTL
 - = 4 for 12 volt proximity detectors
 - = 5 for 5 volt pulse generators or open collector
- vvv** = **Power supply voltage**
- = 110 110 V ac 50/60 Hz
 - = 230 230 V ac 50/60 Hz
 - = 240 240 V ac 50/60 Hz
 - = 024 24 V ac 50/60 Hz
 - = 12d 12 V dc



CI-420 series Electronic Frequency to Analog Converters

The CI-420 series are rail mounting (DIN 46277) micro-processor based control instruments for frequency to analog conversion. They are fully user programable and will adapt directly to any TM44 turbine, COVOL output, or equivalent pulse generating output transducers.

Applications

- Automated process control in any industry with flow rate or volume control for interfacing with PLC and other instruments
- Interface with PLC inputs
- Interface with analog indicators or alarms

Benefits

- Very simple to use, just select frequency for full scale output
- Direct interface to Turbines, Covol etc.
- Fully programable by user
- No batteries needed, BCD switch programming
- Standard DIN rail mounting
- Connections with screw terminals for easy installation and maintenance
- 0-20 mA, 4-20 mA, 0-10 V, 0-5 V, 2-10 V or 1-5 V output options
- Adaptive filter for stable output

Technical Data

- Power supply 110, 230, 240, 24 V ac 50-60 Hz
24 V dc
- Power consumption < 1 VA

- Precision 0.2 % Full Scale
- Temperature range -10°C.....60°C
- Frequency range 0.1.....9999 Hz for full scale
- Cutout frequency 0.04 Hz
- Input signal TM-44 20 mV...3 V ac, 0....2000 Hz
- Input signal COVOL Red contact, 0....100Hz
- Consult Tecfluid for other inputs

Ordering information

CI-420/ a / b / vvv

- a** = **Output signal**
- = A 0 - 20 mA
 - = B 4 - 20 mA
 - = D 0 - 5 V dc
 - = E 0 - 10 V dc
 - = F 1 - 5 V dc
 - = G 2 - 10 V dc
- b** = **Input Type**
- = 1 COVOL
 - = 2 Turbine Pick-up
 - = 3 TTL
 - = 4 for 24 volt proximity detectors
 - = 5 for 5 volt pulse generators or open collector
- vvv** = **Power supply voltage**
- = 110 110 V ac 50/60 Hz
 - = 230 220-230 V ac 50/60 Hz
 - = 240 240 V ac 50/60 Hz
 - = 024 24 V ac 50/60 Hz
 - = 24d 24 V dc

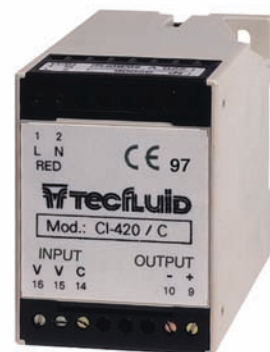

Dimensions: Series DFD-2 (rail DIN 46277)

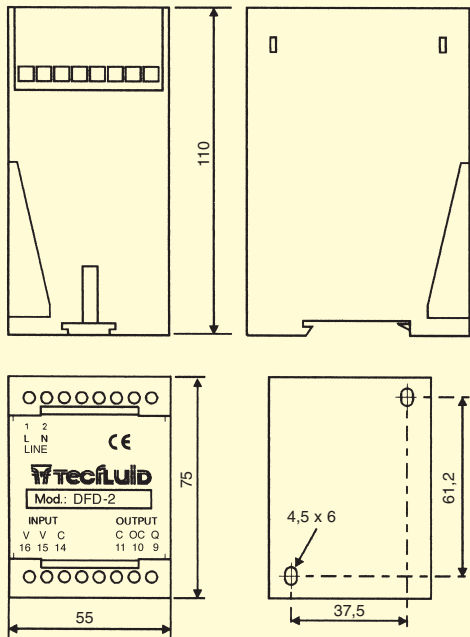

Series CI-420 (rail DIN 46277)

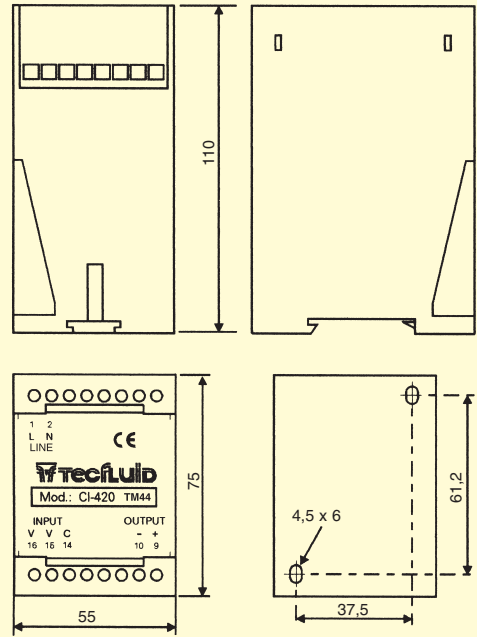

TM44 Turbine Flow Meter Applications

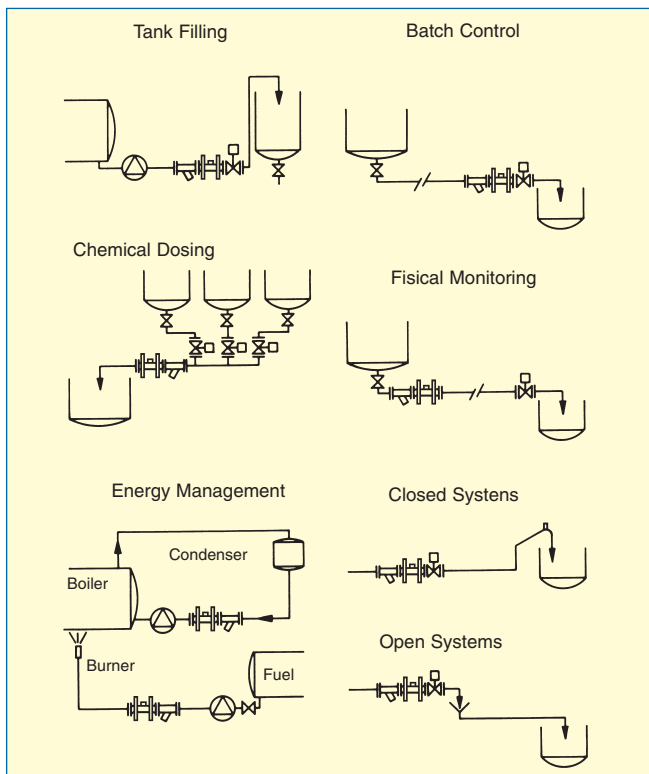

Liquids

- | | |
|---|--|
| <ul style="list-style-type: none"> Acetic Acid Acetone Acrylonitrile Alcohol Ammonia Ammonia Liquids Ammonium Nitrate Anti-coagulants Benzene Butadiene Butane Butene Chlorates Chlorine Condensate Decalcifiers Demineralsed Water Dichloroethane Dimethylamine Diphenoltetrachloride Distillate Esters Ethers Ethiloxide Food products (Cream, Syrups, Fruit Juicea, Vinegar, Wine) Flocculants Food Oils Freon Gasoline Gelatine Glycerine Glycol Hdraulic Oils Hydrocarbons Hydrochloric Acid Industrial Water | <ul style="list-style-type: none"> Inles Isocyanate Isopropylamine Kerosine Liquid Helium Magnesium Sulphate Methanol Methylated Spirits Mineral Oils Menomers Molten Sulphur Natural Gas (Liquidified) Nitric Acid Nitrochlorobenzene Oil & Water Oils and Acids Organic Products Oxigen (Liquidified) Oxigenated Water Pentane Petrol Phosohoric Acid Polybutane Polyol Propane Propylene Propyloxide Silicates Sodium Solvents Sulphuric Acid Toluene Tributyl Phosphate Trichloroethane Vinyl Chlorides Water & Corrosion Water Winhibitors Xylene |
|---|--|