

Ultrasonic level transmitters Series LU



Ultrasonic level transmitter and indicator

- No contact with the product
- Compact design with polycarbonate housing (electronics and display)
- Sensor made of PP or PVDF: very good resistance in corrosive environments, outdoors applications,...
- Easy to program by means of keyboard-display
- Level indication with automatic compensation of temperature changes
- Resolution: 1 mm
- Accuracy: ± 2 mm (between 0.3 and 2 m)
- Low power consumption
- Weight: depending on model, from 1.85 to 2.50 kg
- Remote display available on demand
- Maximum measurable distance:
 - Liquids:
 - Model LU91 / LU921: 6 m
 - Model LU93 / LU923: 12 m
 - Solids:
 - Model LU91 / LU921: 3.5 m
 - Model LU93 / LU923: 7 m
- Connection:
 - Model LU91 / LU921: G2 thread
 - Model LU93 / LU923: G2½ threadOthers on demand
- Continuous level measurement, with 4-20 mA output
- Maximum-minimum level alarms, in 4-wire version (Models LU91 and LU93)
- Optional: HART™ communication protocol



Working principle

A transducer sends short ultrasonic pulses to a product surface. The reflection of these pulses is received back by the same transducer.

The ultrasonic waves travel at the speed of sound. The time passed since the emission of the signal until it is reflected on the product surface (T1) plus the time necessary to receive the signal back on the transducer (T2) determines the distance between the sensor and the product.

The calculation of this distance is carried out by means of a micro-processor with a powerful and smart software which selects the correct echo level among all the echos produced by the internal elements of the tanks.

A temperature sensor built-in the transducer provides the real working temperature to the micro-processor, that makes the proper calculation corrections of the measured distance.

A change in product does not affect the correct performance of the instrument, so it is not necessary to re-adjust the unit for each new product. The non-invasive level transmitter makes installation and maintenance easier.

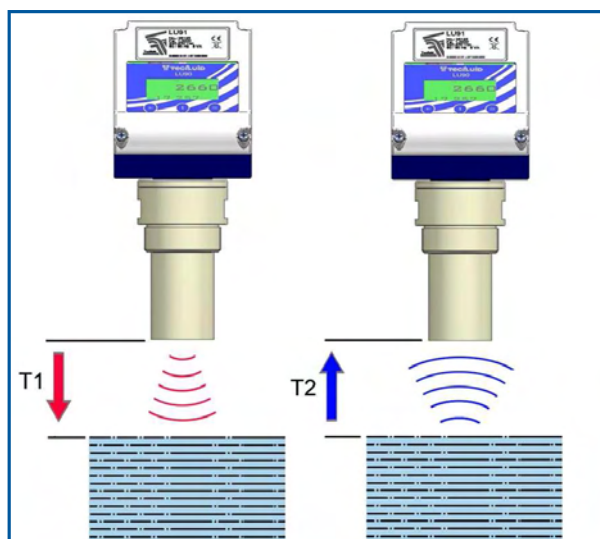

Applications

- Level control in storage tanks of chemical and petrochemical products, treated water, waste water, rainwater,...
- Level control in storage silos of powder, granular products,...
- Level control of food products (sauces, pastry, syrup, etc.) and drinks (wine, milk, mineral water, cola drinks, etc.)
- Flow measurement in open channels, in combination with the electromagnetic sensor series FLOMAT (signal integration software not supplied)
- Control of paper, cardboard, steel and plastic reels
- Control of intermediate tanks for processes such as pumps start-stop, valve opening-closing, etc.

Technical data

Mechanical specifications

- Models:
 - LU91 ... 921 ... 93 ... 923 / PP ... PVDF
 - LU91H ... 921H ... 93H ... 923H / PP ... PVDF
- Ingress protection: IP67
- Materials:
 - Sensor: PP / PVDF
 - Housing / Seal: Polycarbonate (UV treated) / NBR
- Connections:
 - LU91 / LU921: G2 or 2" NPT
 - LU93 / LU923: G2½ or 2 ½" NPT
 Other connection standards on demand
- Weight: from 1.8 to 2.5 kg depending on process connection

Application specifications

- Working pressure: min. 0.7 bar abs ; max. 4 bar abs
- Process temperature: -40 ... +80°C
- Ambient, storage and transportation temperature:
 - Transducer: -40 ... +80°C
 - Electronics: -40 ... +60°C
- Resistance to mechanical vibrations: 4G between 5 ... 100Hz

Measurement specifications

- Resolution: 1 mm
- Uncertainty and repeatability: < 0.25% of the span
- Measuring range
 - LU91 / LU921: liquids: 0.30.....6 m ; solids: 0.30.....3,5 m
 - LU93 / LU923: liquids: 0.45.....12 m ; solids: 0.45.....7 m
- Measurement interval: 200 ms
- Ultrasonic beam width: 14° at -3dB

Reference conditions: Temperature: +18 ... +30°C
Air relative humidity: 45 ... 75% ; Air pressure: 860 ... 1060 mbar

Electrical specifications

- 2-wire (LU921 / LU923) and 4-wire system (LU91 / LU93)
- 4-20 mA output active or passive (HART™ with series LU90H)
- In 4-wire version, maximum-minimum level alarms, full range adjustable. NPN opto-isolated transistor output: V max.: 30 VDC ; I max.: 30 mA
- Power supply:
 - 2-wire: 12 ... 36 VDC
 - 4-wire: 18 ... 30 VDC (special: 14 ... 25 VDC)
- Power consumption: < 20 mA (2-wire) ; < 60 mA (4-wire)
- Cable entries: by means of cable glands for cables with external diameter between 6 and 10 mm
- Programming by means of keyboard and display
- Remote display available on demand

Accuracy diagram

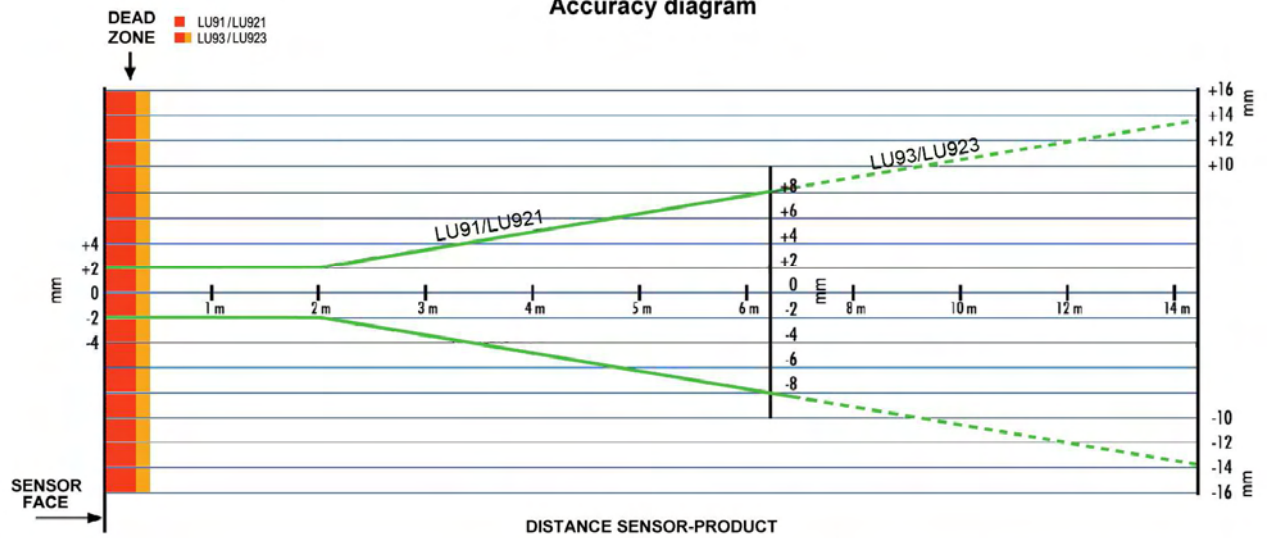

Materials

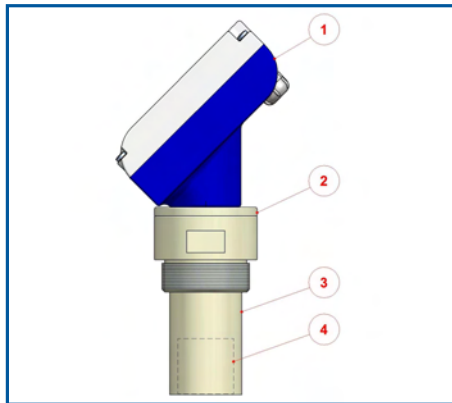

N°	Part	PP	PVDF
1	Housing	Polycarbonate *	
2	Seal	NBR	
3	Sensor	PP	PVDF
4	Transducer	PVDF	

* UV treated

Dimensions

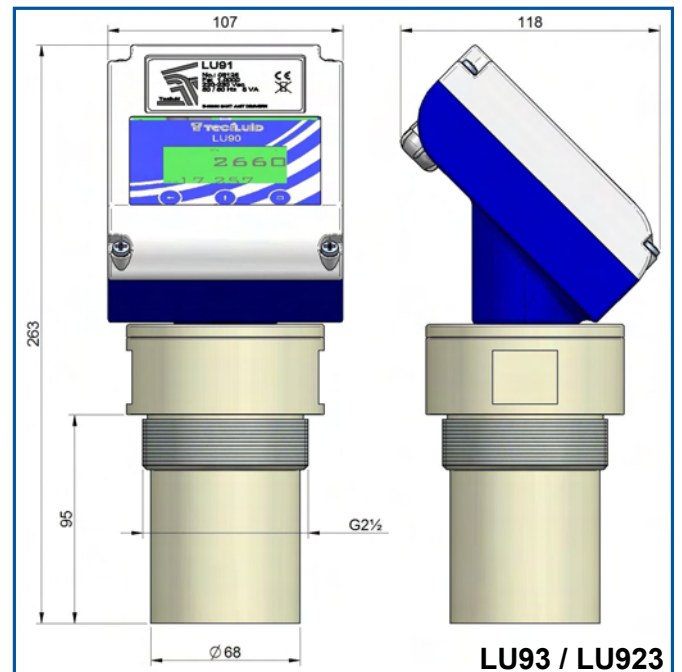
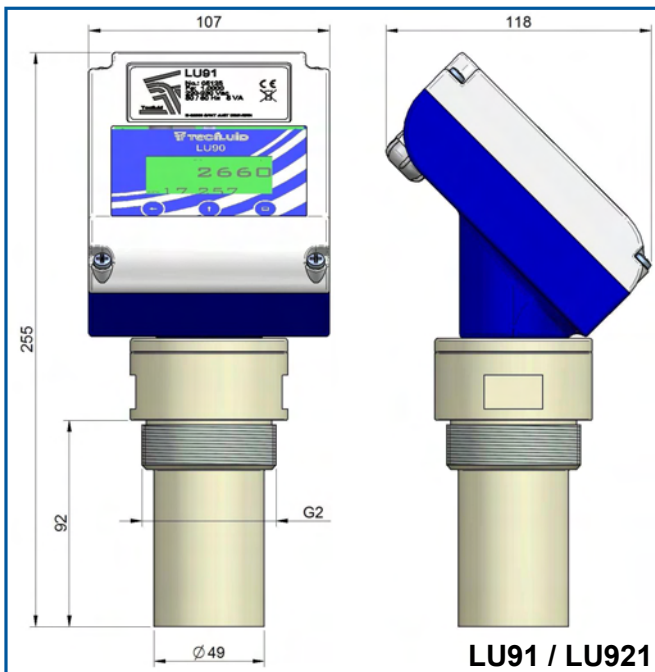

Operation

The installation of the level transmitter must be carried out making sure that the transducer flat face is as parallel as possible to the product surface, in order to guarantee a correct measurement.

The minimum distance with respect to the tank wall must be at least 200 mm, avoiding the sensor to be centred in the tank, especially in cases with agitators or formation of emptying cones (Fig. 1).

Dead zone

The dead zone is a zone close to the transducer, where the instrument is unable to make any measurement (Fig. 2).

For model LU91 / LU921, dead zone is 300 mm, while for model LU93 / LU923, it is 450 mm.

Reduction of dead zone (Fig. 3)

In case of being necessary to reduce the dead zone, reflecting elements can be installed. This allows measurements to be made up to the maximum height of the tank.

Nozzles (Fig. 4)

The length of the sensor must be taken into account and it must be ensured that it protrudes at least 10 mm from the edge of the nozzle.

d	l	h max.
50 mm (2")	> 10 mm	80 mm (3")
65 mm (2 1/2")	> 10 mm	80 mm (3")
100 mm (4")		300 mm (12")
150 mm (6")		400 mm (16")

Common installations

Open channels

Level measurement in open channels.

Open tanks (Fig. 5)

Classical application of measurement and control of liquid level, even with suspended solid particles.

Pressurized tanks

Level control of all kind of liquids, with maximum pressure of 4 bar abs. When working pressure is lower than 0.7 bar abs other measurement systems must be used, such as float type, radar, guided radar, etc..

Tanks with conical bottom (Fig. 6)

Except in tanks with conical bottom, it can be advantageous to install the sensor in the center of the tank, since in almost all the cases it allows to make closer measurements to the bottom of the tank (depending on tank diameter). The formation of emptying cones must be taken into account.

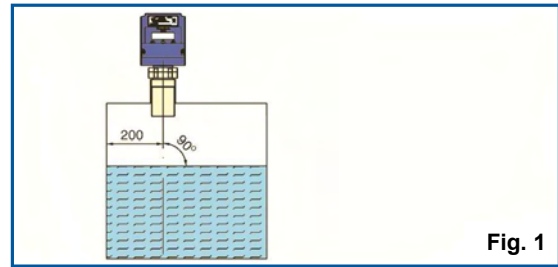

Fig. 1

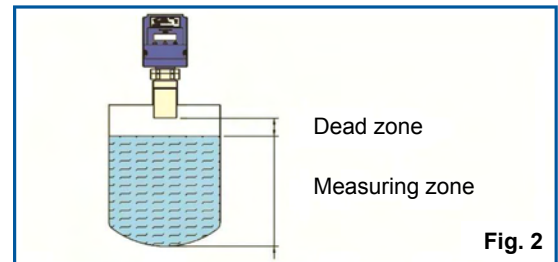

Fig. 2

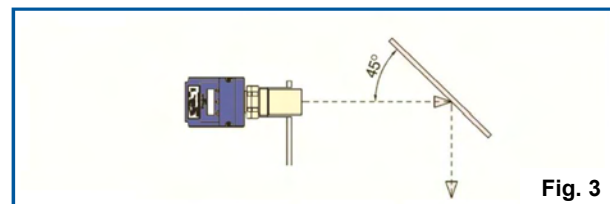

Fig. 3

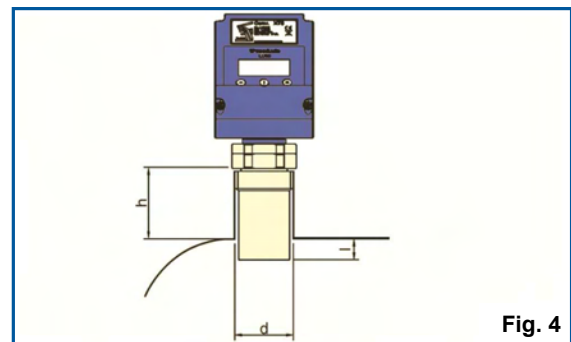

Fig. 4



Fig. 5

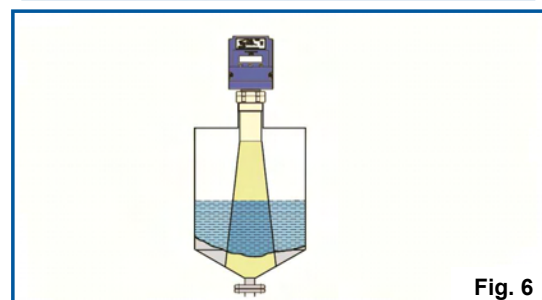

Fig. 6

Mud containers (Fig. 7)

Control of containers filling, by means of conveyors belts, with mud coming from water treatment processes. The minimum distance to tank walls must be bigger than 200 mm.

Product inlets or filling areas (Fig. 8)

It must be ensured that the sensor is installed above the product surface, and not around the filling area or close to the product inlet.

In case of partial or total presence of thick foams on the product surface and for open tanks with possible sudden level changes, strong winds or turbulences caused by cyclones, the sensor must be mounted inside a protecting tube with length equal to the minimum measuring level, planning an aeration orifice of around 5 ... 10 mm of diameter.

Agitators (Fig. 9)

The disturbing echo caused by the agitator must be stored into sensor memory, so it is ensured that the reflections due to the agitator will not be taken into account in the following measurements.

Tanks internal structures (Fig. 10)

In tanks where there are internal structures such as steps, heating-cooling coils, struts, etc. disturbing echoes which might interfere with the correct echo may occur.

If disturbing echoes cannot be avoided, they can at least be minimized by means of small metallic or plastic covers which diffuse the wave reflections, avoiding the direct reception of said waves by the transducer.

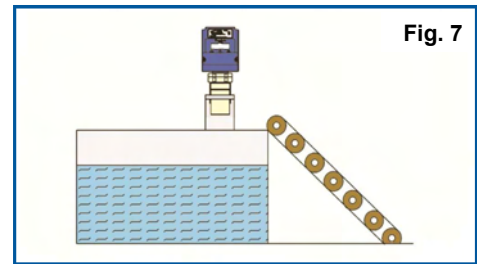

Fig. 7

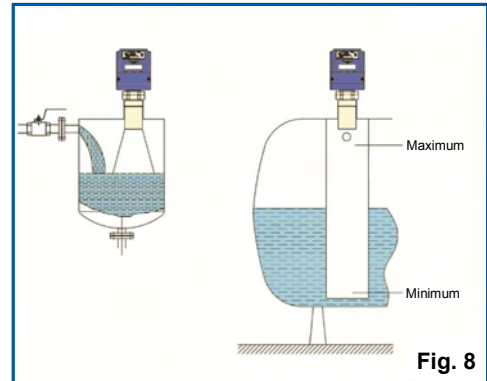

Fig. 8

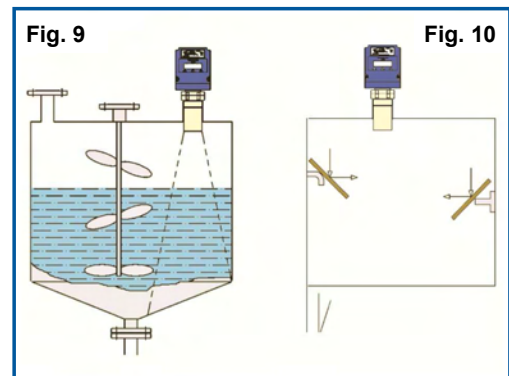

Fig. 9

Fig. 10

HART™ communication protocol

The level transmitters series LU90H are compatible with HART™ communication protocol. The characteristics details are available in the "Field Device Specification" document. In order to proceed with HART™ communication, an external resistance (R ext.), of between 200 and 500 Ohm, must be connected to the current loop. The positions where a terminal or a PC with modem HART™ can be connected are shown in the following figure.

